

---

# THE-100 Series

---

액체정량토출시스템 Since1994

## PRECISION LIQUID DISPENSING TECHNOLOGY



User manual

 **TAEHA** Corporation

## Contents

1	Safety precautions .....	3
2	General information.....	7
2.1	General information.....	7
2.2	Warranty.....	7
2.3	Technical support.....	7
2.4	Precautions.....	8
3	Features of THE-100 series.....	9
3.1	THE-100 series.....	9
3.2	Appearance and specification.....	10
4	Name and function of each part.....	11
5	How to use .....	13
5.1	Ready.....	13
5.2	Negative pressure adjustment.....	14
5.3	Needle, Barrel internal air bubble removal .....	14
5.4	Dispensing rate adjustment.....	15
5.5	Interval function(Intermittent dispensing).....	15
6	Input / output relationship.....	16
6.1	Control terminal .....	16
6.2	Timing chart .....	16
7	Maintenance consumables.....	18

## 1 Safety precautions

---

This manual is applied to products manufactured and sold by Taeha Corp. (here in after referred to as “our company”) and, therefore must not be used in partial or full copy without permission of our company.

This manual explains the specifications, installation, wiring, maintenance check, abnormal phenomena and measures to be taken for our products. When using this product, please read this manual carefully, pay enough attention to safety and handle it properly.

The safety precautions have been classified into “Danger” and “Caution”.



“**Danger**” means that dangerous situations can occur and death or serious injury could result, if handled incorrectly.



“**Caution**” means that dangerous situations can occur if handled incorrectly. Also you may get serious injury or physical damage.

In addition, even if it is indicated as caution, it may lead to serious consequences depending on the situation. Since this is important for the safety of the user, please make sure you follow the instructions.



#### Precautions against electric shock

##### Danger

1. This equipment is kept under high pressure for a while even after the main power supply is cut off. When performing a wiring work or inspection that touches all terminals of the terminal block, leave it for at least five minutes after shutting off the power before you start the work.
2. To prevent electric shock and malfunction, please provide class 3 grounding (100Ω or less, wire diameter 1.6mm or thicker).
3. Inspection and maintenance of this equipment must be performed by a qualified technician(specialist).
4. Do not inspect equipment with wet hands, when the floor is wet or if there is too much moisture. It may cause electric shock.
5. Be careful not to damage the cable, place heavy objects on it or fold it. In case it is damaged, it may cause electric shock.

#### Precautions against fire



##### Danger

1. Do not install this equipment near inflammables, combustible organic solvents or vapors. The heat and electrical operation can cause fire.
2. If this equipment malfunctions, disconnect the main power supply of the equipment. The high current may cause a fire.

#### Precautions of wiring



##### Danger

1. Before conducting wiring work for maintenance etc., be sure to shut off all the external power supplies used by the equipment.  
Failure to do so may result in electric shock or damage to the equipment.
2. To supply power or operate the equipment after wiring, be sure to attach the covers inside and outside the equipment. Failure to do so may result in injury and electric shock.



#### Caution

1. Do not apply main power supply except for that of the voltage specified in this user manual. It may cause malfunction.
2. Make sure that terminal connections and wiring are correct. It may cause malfunction.
3. While the electric current is being applied, do not change the wiring or detach the connector. It may cause injury or equipment failure.
4. If the power wiring in the driving area is wrong, it may cause injury or damage to the equipment due to malfunction. Be careful.

#### Precautions on installation



#### Caution

1. Do not install, store and use in places exposed to conductive dust, corrosive gas, flammable gas, high temperature, condensation, wind and rain, etc.
2. Exposure to direct sunlight for a long time will degrade accuracy of the equipment. Do not install, store or use in areas where there is direct sunlight.
3. When installing in an enclosed space, install a separate cooling fan to allow the outside air to flow in and out, in order to maintain the temperature around the equipment at 40°C or less. Overheating may cause fire or other accidents.

#### Precautions on use



#### Caution

1. Never modify this equipment. It may cause electric shock, injury, fire or breakdown.
2. Once you modify this equipment, it cannot be covered by our warranty for defects.
3. Before use, be sure to check that all covers are properly installed and verify if there is no foreign material inside the equipment. Depending on the circumstances, unexpected operation can occur and may result in injury.
4. If an alarm occurs during use, remove the cause of the alarm, check the safety, and reuse it.



Danger
<ol style="list-style-type: none"> <li>1. When the equipment of our company is used including robots (multi-joint robot, rectangular coordinate robot, desktop robot), please be sure to install a safety net in the robot operation area, and never approach the operation area during operation.</li> <li>2. Equipment of our company include driving and rotating parts. Install a safety net on the rotating parts and never approach it during operation.</li> </ol>

Precautions for maintenance and inspection



Caution
<ol style="list-style-type: none"> <li>1. When cleaning or repairing the equipment, be sure to turn off the power and check the internal power supply for complete discharging, and then have it carried out by a qualified maintenance specialist. Maintenance by non-experts can cause breakdown.</li> <li>2. If there is a breakdown of the equipment, do not disassemble the equipment. Please contact our customer support team.</li> <li>3. If dust accumulates on the equipment, it may cause malfunction. Clean up the equipment periodically. When cleaning, please shut off the external power completely and check whether the equipment has been fully discharged. There is a danger of electric shock.</li> </ol>

Precautions for disposal



Caution
<ol style="list-style-type: none"> <li>1. When this equipment is disposed of, treat it as industrial waste.</li> </ol>

## 2 General information

---

### 2.1 General information

---

This user manual provides the user and the equipment maintenance specialist with essential information for operating the equipment. Therefore, it is strongly recommended that you should thoroughly understand this user manual.

In order to have easy access to this user manual, it must be placed where it can be easily seen, near the equipment.

### 2.2 Warranty

---

Except for a separate agreement and the following cases, the warranty period will be one year in the event of defects

- Following -

1. In case you modify the equipment without permission by Taeha Corp.
2. If someone other than the technical support personnel of Taeha Corp. modifies the equipment or repairs the equipment without using the designated parts.
3. If any spare parts other than those specified by Taeha Corp. have been used for the product.
4. In case of intentional damage or damage due to consumer's fault
5. In case of natural disasters or fire.

### 2.3 Technical support

---

If necessary, Taeha Corp. will provide technical support service for the customer. Please contact us by phone or fax.

Head Office

Phone : +82(0)31 552 5300

Fax : +82(0)31 552 5400

## Gumi Branch Office

Phone : +82(0)54 463 0014

Fax : +82(0)54 463 0017

## Tianjin Branch Office in China

Phone : +86(0)22 2388 8851~2

Fax : +86(0)22 2388 8853

## Shenzhen Branch Office in China

Phone : +86 755 2373 3819

Fax : +86 755 2373 3519

## Suzhou Branch Office in China

Phone : +86 512 6251 2825

Fax : +86 512 6805 2921

## 2.4 Precautions

---

**Danger**

1. Be sure to use the designated power supply. The basic power of the equipment is designated as AC220V 50/60Hz.
2. Be sure to use the designated air pressure. The basic air pressure of the equipment is designated as 5kgf/cm<sup>2</sup>.
3. Do not operate with wet hands. There is a risk of electric shock.
4. During the operation, do not turn off the power or shut down the air pressure unless the equipment is in danger/caution. Serious problems may arise with the use of equipment.
5. Contact us in case of severe errors in the equipment.



### 3 Features of THE-100 series

---

#### 3.1 THE-100 series

---

THE-100 Series\_automatic fluid dispenser is a precision instrument that uses an advanced microprocessor and air pulse speed-up circuit to make full use of the liquid discharge rate quickly and stably.

Carefully read this instruction manual. Please make sure that the work you want to maximize the performance of the product is performed.



## 3.2 Appearance and specification

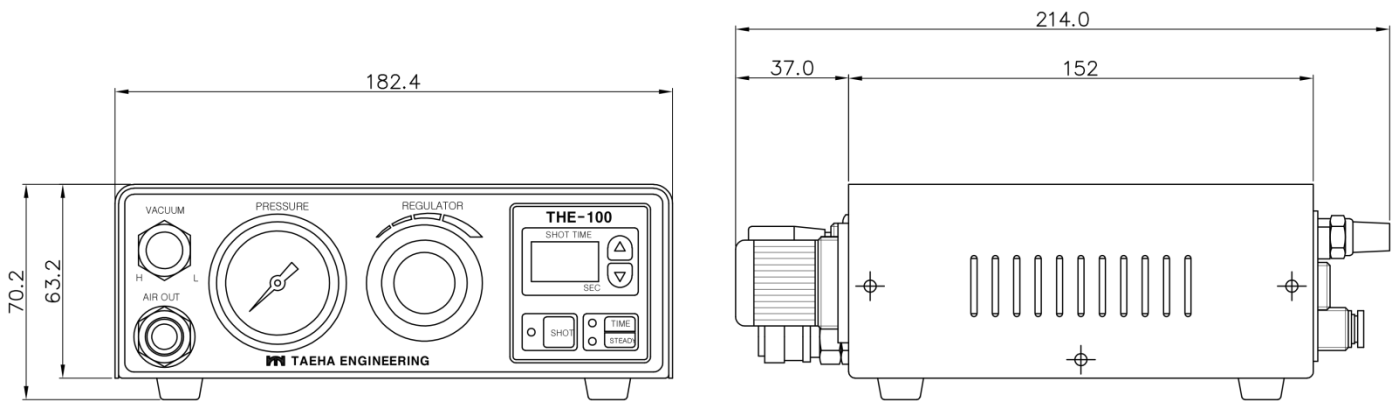
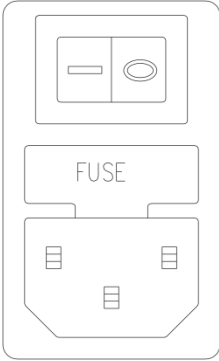
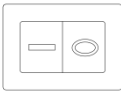

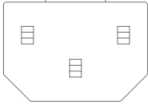
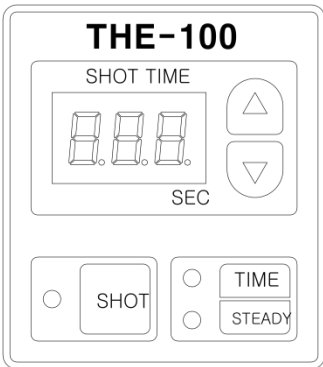
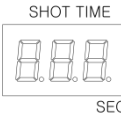

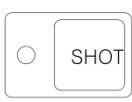

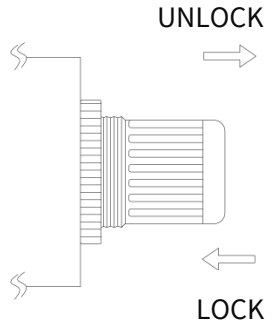

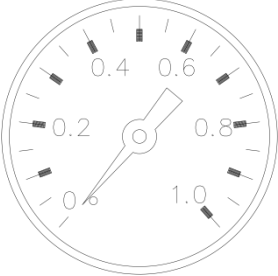
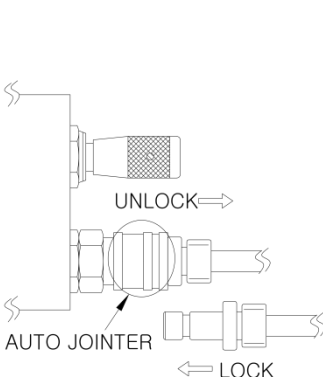
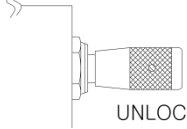

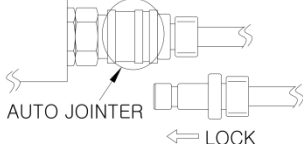

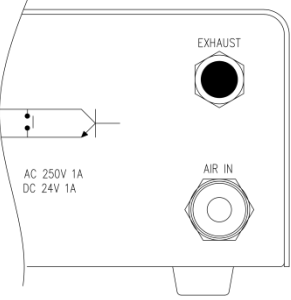



Figure 1. Appearance of THE-100 controller

Table 1. Specification of THE-100 series

Item	THE-100	THE-100E	THE-100R
Valve type	Single action valve		Double action valve
Power	AC 110 or 220V, 50/60Hz		
Power consumption	10 W		
Supply air pressure	Max. 990kPa, oil-free Dry air		
Pneumatic adjustment range	0.02 ~ 0.6 MPa		
Shot time adjustment range	0.03 ~ 9.99 sec		
Operation	Time operation : Fixed quantity dispensing Steady operation : Continuous dispensing Interval operation : Intermittent dispensing		
Input signal	Foot switch, Finger switch(option) Non-voltage N.O contact(maintains input signal)		
Input signal time	Min. 0.1 sec or more		
Shot end signal	N.O Relay contact		
Vacuum	0 ~ 450kPa	X	X
Operating temperature	5 ~ 40°C		
Weight	1.9kg		
Standard accessories	Foot Switch(2m) / Power Cord(1m) / Barrel Stand		

### 4 Name and function of each part

Image	Names and displays	Function									
	 : ER Switch	I : Power ON O : Power OFF									
	 : Holder	Small 0.5 +A Fuse(include spare 1 EA)									
	 : Acceptable	Power cord inlet. (Be sure to process earth.)									
	 : Display	Time mode : Increases by the set value. Steady mode : Increases as signal on.									
	 : Time Up	Press for 2 seconds or more to increase rapidly.									
	 : Time Down	Press for 2 seconds or more to make a rapid descent.									
	 : Shot switch	Time mode : Press once to turn on only the set value. Steady mode : Continue ON while pressing									
	 : Time/Steady select s/w	Time mode : Press once to turn on only the set value. Steady mode : Continue ON while pressing									
		<table border="1"> <thead> <tr> <th></th> <th>Rotate</th> <th>Description</th> </tr> </thead> <tbody> <tr> <td>Raise pressure</td> <td>CW</td> <td>Slowly rotate to the set pressure</td> </tr> <tr> <td>De-compress</td> <td>CCW</td> <td>After setting the pressure lower than the set pressure, raise the pressure</td> </tr> </tbody> </table>		Rotate	Description	Raise pressure	CW	Slowly rotate to the set pressure	De-compress	CCW	After setting the pressure lower than the set pressure, raise the pressure
		Rotate	Description								
Raise pressure	CW	Slowly rotate to the set pressure									
De-compress	CCW	After setting the pressure lower than the set pressure, raise the pressure									
When pressure is set : Unlock state When the pressure setting is completed : Set to the lock state.											

	<p>The indicated value is MPa. 1MPa = 10.2kgf/cm<sup>2</sup></p>	<p>The pressure adjusted from the regulator is displayed. At the time of dispensing, the needle moves at the same time as the operation sound of the solenoid valve.</p>
	 <p>UNLOCK⇒ : Vacuum adjust</p> <p>Increase negative pressure : CCW Decrease negative pressure : CW</p>	<p>If the dispensing material has a low viscosity, the material will be natural fall. Set the negative pressure inside barrel for natural fall prevention.</p>
	 <p>AUTO JOINTER ⇐ LOCK</p> <p>: Air out port</p>	<p>It is the outlet of the set air pressure.</p>
	<p>Connect to a foot switch or external device.</p>	<p>It is a connector for the discharge input signal and the discharge end signal , ⚠ If power is applied to the terminals, it will break down.</p>
	 <p>EXHAUST : Exhaust</p>	<p>Pressure release in Barrel and Vacuum generator outlet. Keep it clean so that there are no foreign objects. After the discharge is completed, it may cause poor decompression and drop in pressure ,</p>
	 <p>AIR IN : Air in</p>	<p>Air supply to the controller. Install the outer diameter Ø6 air tube.</p>
	<p>Foot Switch</p>	<p>Tighten after inserting it into the control connector. Click to give a discharge signal to the controller .</p>
	<p>Power cord</p>	<p>Be sure to perform earth processing..</p>

5 How to use

5.1 Ready

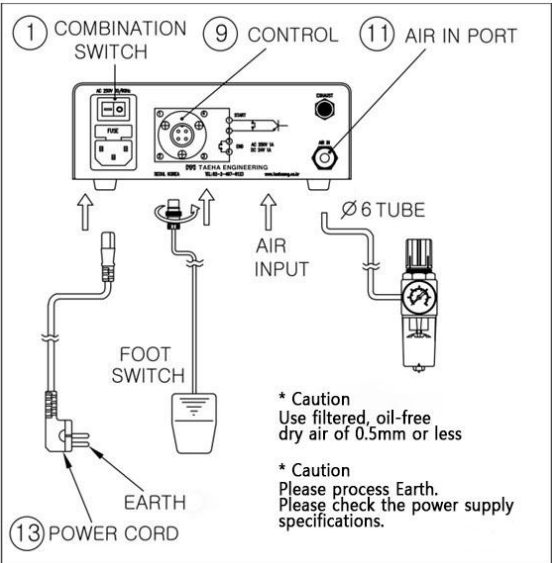
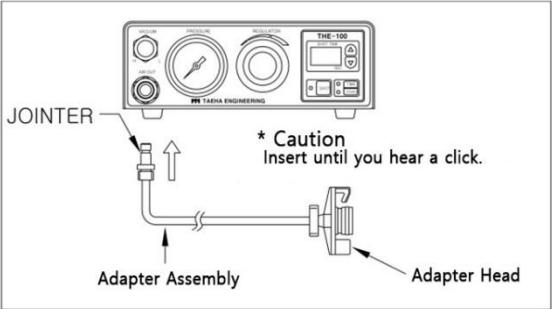
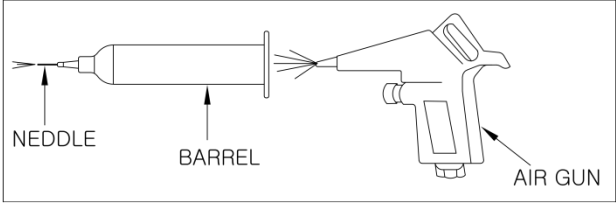
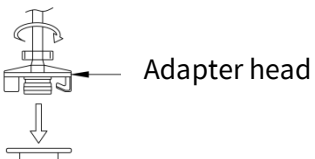
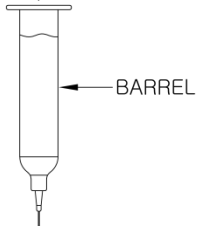
No.	Image	Description
1		<p>1-1) Supply air with a maximum of 0.9MPa to the outer diameter Ø6tube.</p> <p>1-2) Insert the Power cord.</p> <p>1-3) After inserting the Foot switch into the control terminal, turn the screw to firmly attach it.</p> <p>1-4) Turn on the Combination switch.</p> <p>When turned on, the lamp lights up.</p>
2		<p>Insert the joint of the adapter assembly into the Air out port on the front of the controller.</p>
3		<p>Before adding material, clean the barrel and needle with dry air to prevent foreign matter.</p>
4		<p>Put the material so that it does not contain air bubbles. Fill up to 70-80% of the barrel capacity, and wipe off any liquid on the top 1-2 cm.</p>
5		<p>Insert the adapter assembly head into the barrel head and rotate it 90 ° afterwards to prevent it from coming off.</p>

### 5.2 Negative pressure adjustment

No	Image	Description
1		<p>If the material falls naturally on the tip of the Needle, we are adjusting the Vacuum.</p> <p>Turning the handle on the front of the controller counterclockwise creates negative pressure to prevent free fall.</p> <p>⚠ Caution</p> <ul style="list-style-type: none"> <li>- If the negative pressure is too large, air bubbles will be generated inside the barrel and the material after discharge can be sucked, so set the negative pressure appropriately..</li> <li>-Please note that when negative pressure is generated, the material in the controller may be sucked by tilting the barrel severely, which may cause a malfunction.</li> </ul>

### 5.3 Needle, Barrel internal air bubble removal

No	Image	Description
1		<ul style="list-style-type: none"> <li>- If there are air bubbles in the Needle or barrel, set it to low pressure and then operate slowly in steady mode until the air comes off.</li> <li>- Replace needle.</li> </ul>

### 5.4 Dispensing rate adjustment

No	Description													
1	<table border="1"> <tr> <td>Adjustment</td> <td>Decrease</td> <td>Increase</td> </tr> <tr> <td>Needle</td> <td>thickness ↓</td> <td>thickness ↑</td> </tr> <tr> <td>Pressure</td> <td>low</td> <td>High</td> </tr> <tr> <td>Dispensing time</td> <td>time ↓</td> <td>time ↑</td> </tr> </table>	Adjustment	Decrease	Increase	Needle	thickness ↓	thickness ↑	Pressure	low	High	Dispensing time	time ↓	time ↑	<p>1) Adjust to Steady mode (continuous dispensing).</p> <p>2) Gradually increase to the desired discharge rate at the appropriate (desired) flow rate.</p> <p>3) You can also adjust the discharge pressure to set the desired flow rate and discharge amount.</p> <p>⚠ Caution</p> <ul style="list-style-type: none"> <li>- At first, adjust the discharge amount to a needle of appropriate thickness by gradually boosting the pressure from low pressure.</li> <li>- Please note that there is a risk of material scattering if the Needle is thick and high pressure.</li> </ul>
Adjustment	Decrease	Increase												
Needle	thickness ↓	thickness ↑												
Pressure	low	High												
Dispensing time	time ↓	time ↑												
2	<p>Factors that can change the discharge rate</p> <table border="1"> <tr> <td>Dispensing time</td> <td>Small amount</td> </tr> <tr> <td>Needle change</td> <td>Middle amount</td> </tr> <tr> <td>Pressure</td> <td>Large amount</td> </tr> </table>	Dispensing time	Small amount	Needle change	Middle amount	Pressure	Large amount	<p>1) Operate in Steady mode until the desired discharge amount is shot s/w or foot s/w.</p> <p>2) At this time, after memorizing the number in shot time, select time mode and set the time with the augmentation key.</p> <p>3) With the time mode selected, proceed with the discharge test and check if the discharge amount is the one you want.</p>						
Dispensing time	Small amount													
Needle change	Middle amount													
Pressure	Large amount													

### 5.5 Interval function(Intermittent dispensing)

No	Image	Description
1	<p>* Intermittent dispensing : A function that repeatedly turns the machine ON and OFF while the shot signal is ON</p>	<p>1) Press the Time and Steady keys on the front of the controller for 3 seconds, and the shot time display will blink.</p> <p>2) Use after setting the off time of the increase / decrease key.</p> <p>3) After setting to low pressure, operate slowly in steady mode until air comes off.</p>

## 6 Input / output relationship

### 6.1 Control terminal

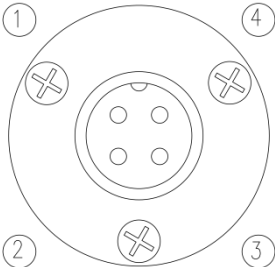
Image	Description
<p style="text-align: center;">CONTROL</p> 	<ul style="list-style-type: none"> <li>- Terminal number 1, 2 : Shot input signal</li> <li>- Terminal number 3, 4 : Shot signal end(Relay contact)</li> </ul> <p>⚠ Caution</p> <ul style="list-style-type: none"> <li>- Please note that applying power to the terminals may cause a malfunction.</li> </ul>

### 6.2 Timing chart

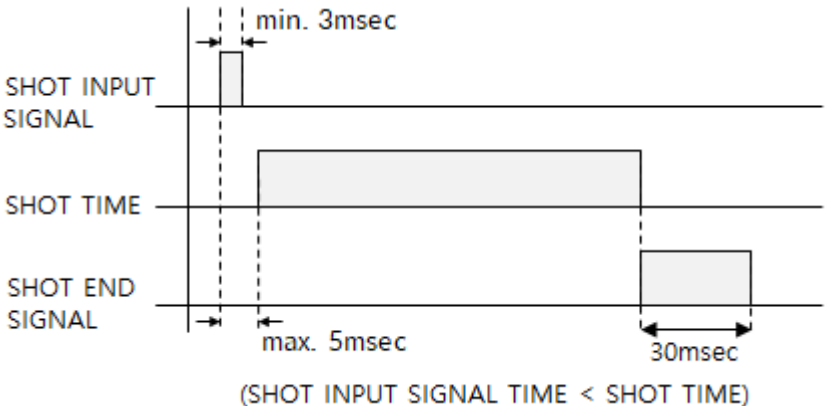
Timing chart	Description
<p style="text-align: center;">TIME</p>	 <ul style="list-style-type: none"> <li>- Shot input signal holding time : Min. 3msec</li> <li>- SHOT TIME occurrence delay time : Max. 5msec</li> <li>- Shot end signal time : 30msec</li> </ul>

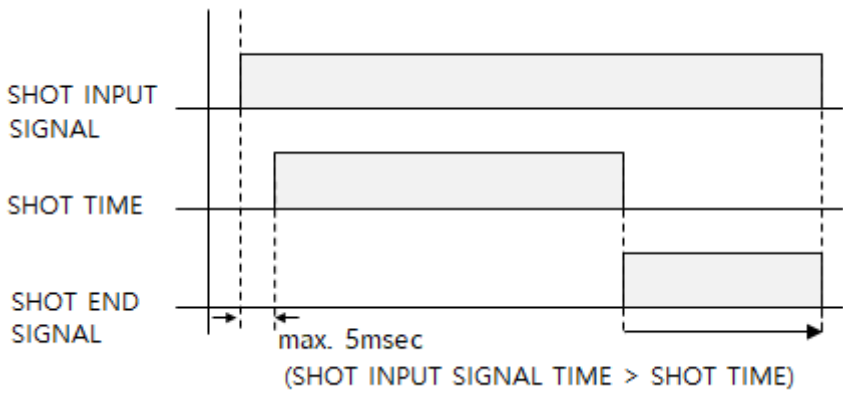
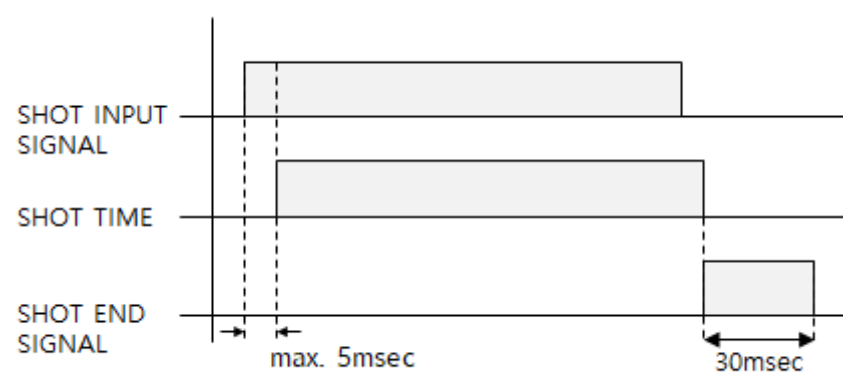
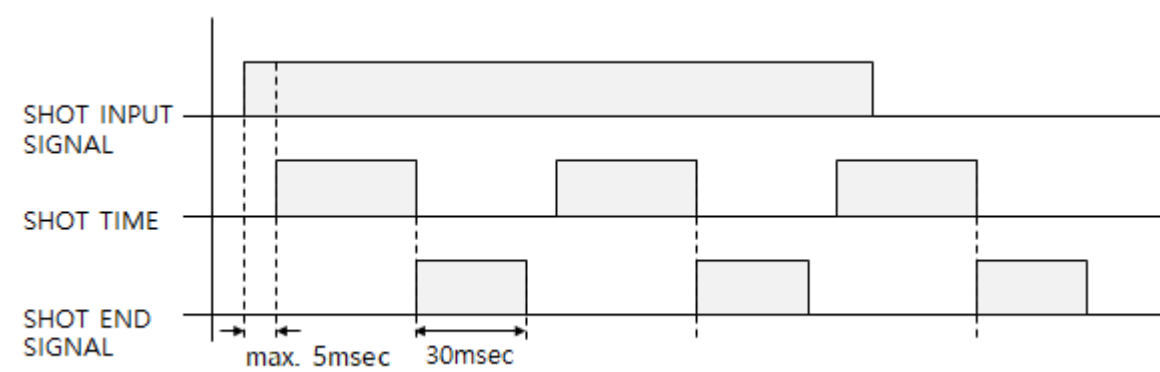

<p>TIME</p>	 <p>- When shot input signal time &gt; shot time, the shot end signal is maintained up to the shot input signal.</p>
<p>STEADY</p>	 <p>- Shot input signal holding time : Min. 3msec          - SHOT TIME occurrence delay time : Max. 5msec          - Shot end signal time : 30msec</p>
<p>INTERVAL</p>	 <p>- Shot input signal holding time : Min. 3msec          - SHOT TIME occurrence delay time : Max. 5msec          - Shot end signal time : 30msec          - Shot end signal generated after every shot time.</p>

## 7 Maintenance consumables

---

- 1) If the O-Ring of the adapter assembly is solidified with solvent and damaged material, replace it with a new product.
- 2) Do not use the product if the barrel is scratched or damaged.  
(Barrel is disposable. Replace it after it has been used for metered dispensing.)
- 3) Adapter assembly, barrel, needle, o-ring, etc. are consumables. Please specify the size and part number when ordering.
- 4) If any trouble occurs or repair is required, please contact us if you have any concerns.